

Table of Contents

General Requirements

1. Warranties
2. Equipment Capacity
3. Energy Efficiency
4. Efficiency Nova Scotia Rebates
5. Equipment Isolation
6. Placement of Equipment And Equipment Access
7. Mechanical Rooms
8. Electrical Rooms
9. Special Procedures for Third Party Equipment Integration Into Campus BMS

Division 23 - HVAC

- 23 05 19 Meters and Gauges for HVAC Piping
- 23 05 19.13 Thermometers and Pressure Gauges - Piping Systems
- 23 05 53 Identification for HVAC Piping and Equipment
- 23 07 13 Duct Insulation
- 23 07 19 HVAC Piping Insulation
- 23 09 23.14 Flow Instruments
- 23 09 43 Pneumatic Control System for HVAC
- 23 21 13.01 Hydronic Systems: Copper
- 23 21 13.02 Hydronic Systems: Steel
- 23 21 23 Hydronic Pumps
- 23 22 13 Steam and Condensate Heating Piping
- 23 22 13.13 High Pressure Steam and Condensate Heating Piping Systems
- 23 23 00 Refrigerant Piping
- 23 30 00 HVAC Air Distribution
- 23 33 00 Air Duct Accessories – Flexible Connectors
- 23 33 15 Dampers - Operating
- 23 33 46 Flexible Ducts
- 23 34 23.13 Packaged Roof and Wall Exhausters
- 23 36 00 Air Terminal Units
- 23 37 13 Diffusers, Registers and Grilles
- 23 57 00 Heat Exchangers for HVAC
- 23 65 10 Condensers, Coolers and Cooling Towers
- 23 72 00 Air-To-Air Energy Recovery Equipment

Div 23(a) - HVAC Design Guidelines 2024 05 15 (5)

- 23 73 00.13 Air Handling - Built-Up
- 23 73 00.16 Air Handling Units - Packaged
- 23 74 00 Packaged Outdoor HVAC Equipment
- 23 81 23 Computer Room Air Conditioning
- 23 81 40 Air and Water Source Heat Pumps
- 23 83 02 Hot Water Radiant In-Floor
- 23 84 13 Humidifiers

Div 23(a) - HVAC Design Guidelines 2024 05 15 (5)

Dalhousie University Design Guidelines provide assistance to consultants during the planning, and design phases of the University's expansion and renovations. The Guidelines do not relieve a consultant from any professional responsibility, duty or due diligence to design elegant, functional, efficient and low maintenance facilities.

Facility owners have preferred materials and requirements that make the task of maintaining facilities less costly. Dalhousie understands this is a balance between capital and operating cost. The Guidelines are not intended to be the only acceptable solution. Dalhousie expects consultants to bring modern and innovative ideas, materials and methods to the University. If these Guidelines do not allow these new ideas then the consultant is to make a request in writing to the Dalhousie Project Manager for an exception to the guidelines. Necessary reasoning and or calculations shall accompany the request. The exception request will be reviewed internally and either rejected or accepted. The consultant will document this rational and/or justification for each exception in the Basis of Design. The University Guidelines may be updated subsequently.

These documents provide design guidelines only, and are not intended for use, in whole or in part, as a specification. Do not copy the guidelines verbatim in specifications or in notes on drawings. Refer questions and comments regarding the content and use of these documents to the Dalhousie University Project Manager. The Guidelines are intended to be read in conjunction with the local codes and regulations, and in no way are to be considered as a code replacement. The codes and regulations represent the minimum acceptable standard. Where the technical design requirements differ from the building codes and other applicable codes and standards, the more stringent of the codes shall be applied.

Maintaining the Standards/Guidelines

The Design Guidelines are created and maintained by Dalhousie's Facilities Management Department. Any enquiries about the Guidelines should be directed to Facilities Management, Director of Projects, Central Services Building. Dalhousie encourages design specialists and other interested parties to provide their input and suggestions based on their experience.

Div 23(a) - HVAC Design Guidelines 2024 05 15 (5)

MECHANICAL CONSULTANT COMPLIANCE CHECKLIST

	C	NC	NA
General Requirements			
1. Warranties			
2. Equipment Capacity			
3. Energy Efficiency			
4. Efficiency Nova Scotia Rebates			
5. Equipment Isolation			
6. Placement of Equipment And Equipment Access			
7. Mechanical Rooms			
8. Electrical Rooms			
9. Special Procedures for Third Party Equipment Integration Into Campus BMS			
Division 23 - HVAC			
23 05 19 Meters and Gauges for HVAC Piping			
23 05 19.13 Thermometers and Pressure Gauges - Piping Systems			
23 05 53 Identification for HVAC Piping and Equipment			
23 07 13 Duct Insulation			
23 07 19 HVAC Piping Insulation			
23 09 23.14 Flow Instruments			
23 09 43 Pneumatic Control System for HVAC			
23 21 13.01 Hydronic Systems: Copper			
23 21 13.02 Hydronic Systems: Steel			
23 21 23 Hydronic Pumps			
23 22 13 Steam and Condensate Heating Piping			
23 22 13.13 High Pressure Steam and Condensate Heating Piping Systems			
23 23 00 Refrigerant Piping			
23 30 00 HVAC Distribution			
23 33 00 Air Duct Accessories – Flexible Connectors			
23 33 15 Dampers - Operating			
23 33 46 Flexible Ducts			
23 34 23.13 Packaged Roof and Wall Exhausters			
23 36 00 Air Terminal Units			
23 37 13 Diffusers, Registers and Grilles			
23 57 00 Heat Exchangers for HVAC			
23 65 10 Condensers, Coolers and Cooling Towers			
23 72 00 Air-To-Air Energy Recovery Equipment			
23 73 00.13 Air Handling - Built-Up			
23 73 00.16 Air Handling Units - Packaged			
23 74 00 Packaged Outdoor HVAC Equipment			

FACILITIES MANAGEMENT

Central Services Building | 1236 Henry Street | PO Box 15000 | Halifax NS, B3H 4R2 Canada

DAL.CA

Div 23(a) - HVAC Design Guidelines 2024 05 15 (5)

General Requirements

1. Warranties

- A. Standard 12 month warranty for a project begins at Substantial Performance. Systems and or equipment that is not considered complete at the time of the project's (or trade's) Substantial Performance shall be noted as such on the Substantial Performance Certificate's Punch List. Warranty for this equipment (or system) shall be one year from the date upon which it is removed from the Punch List.
- B. Extended warranties are available for many pieces of equipment and/or products from the manufacturer. Dalhousie requires suppliers/manufacturers to provide such extended warranties directly to the Owner in the name of Dalhousie University. A list of such warranties will be reviewed with the Owner at time of shop drawing submission.
- C. The designer shall recommend any extended warranties (including labour) and/or service agreements to the Owner. In all cases, these shall be listed as alternative prices to the base project on the bid form.

2. Equipment Capacity

- A. Where a future expansion to an air handling unit is possible, it shall be sized to have 20% excess capacity when operating at peak design capacity and the air filters are dirty (defined as air filters are at half-life). If a VFD is applied, at this condition it shall not exceed 48 Hz to achieve design air flow rates.
- B. Electrical Motors
 - a. No electrical motor shall operate in excess of 80% of its FLA at peak design conditions. If a VFD is applied, at this condition it shall not exceed 48 Hz.
 - b. Under no circumstances shall a motor, by design and/or at design operation, ever exceed 48 Hz. Direct coupled fans within Air Handling Units are a specific example of where this is not permitted.

3. Energy Efficiency

- A. Wet Heating Systems shall be designed for a maximum Entering Water Temperature (EWT) of 140 F.
- B. Variable frequency drives should be used for all 3 phase motors on HVAC equipment that would traditionally require a starter. Specification must state that the associated Efficiency Nova Scotia rebate is to be payable to the University. See Section 4.
- C. Heat Recovery Systems, where practical, are preferred wherever possible. Air to Air, water to water and steam transitional pressures.
- D. Use of Triple Duty Valves in hydronic installations
 - a. Common practice is to install a pump with a shut-off valve, suction diffuser, pump, triple-duty valve and shut-off valve. Triple-duty valve are not to be installed. A check valve shall be installed in its place.

Div 23(a) - HVAC Design Guidelines 2024 05 15 (5)

4. Efficiency Nova Scotia Rebates

A. Energy efficiency must be considered and equipment specifications must align with those identified by Efficiency Nova Scotia as eligible for Business Energy Rebates. The rebates include but are not limited to the following categories:

- Compressed Air
- Hot Water Heating
- HVAC
- Motors & Variable Speed Drives
- Refrigeration Equipment

The specifications identified by Efficiency Nova Scotia are available on their website <https://www.energycyns.ca/business/products/>

5. Equipment Isolation

A. All equipment shall be able to be individually isolated (mechanically & electrically).

6. Placement of Equipment And Equipment Access

- A. As necessary the Designer shall summarize all work necessary to place equipment or systems into existing spaces. Including but not limited to: wall removals, door removals, special cranes, or knock down equipment.
- B. The ability to service equipment, including necessary permanent platforms, shall be reviewed with the Project Manager as part of the shop drawing review/approval. Exceptions to the manufacturer's recommended clearance requirements, shall be identified during the shop drawing review/approval stage by the designer.
- C. The internal dimension of all access doors and panels must be a minimum of 12" x 18". Access doors shall be hinged with a positive locking mechanism.
- D. Equipment shall not be placed closer than 3 meters (2 meters from the roof edge plus 1 meter for servicing room) from the edge of any roof. If this is not possible, appropriate engineered barriers shall be provided.
- E. Equipment should be located with consideration of snow accumulation, entry into equipment and removal. As well as protected from University snow removal operations. Where snow accumulation is inevitable, designer is to complete a structural analysis.
- F. Equipment to be placed on the roof must include a detailed drawing of sleepers, penetrations, etc. It is the responsibility of the Designer to ensure the detailed drawing is signed off by a qualified roofing professional and ensure roof warranties are not voided by works carried out.

Div 23(a) - HVAC Design Guidelines 2024 05 15 (5)

7. Mechanical Rooms:

- A. Provide floor drains.
- B. Mechanical rooms shall not be used as an air plenums. Exceptions are to be presented to the University for the Project Manager's approval.

8. Electrical Rooms

- A. Electrical Rooms shall be positively pressurized, if possible.
 - a. If using a fan coil for cooling, this is not applicable.
 - b. If using outdoor air for cooling, a powered air supply fan shall be used with a dampered only exhaust outlet in lieu of a powered air exhaust fan and a dampered only outdoor intake. Outdoor air is to be filtered, MERV 8.

9. Special Procedures for Third Party Equipment Integration Into Campus BMS:

- A. Division 01 35 13.01 to 13.03 deals with third party equipment that has a microprocessor based controller whose information is to be integrated into the campus' Building Management System (BMS); Johnson Controls Metasys for Halifax campuses and Delta Controls enteliWEB for Bible Hill. The mechanical and/or electrical consultant are responsible to identify equipment that is to be integrated and make reference to these three Division 1 sections in that equipment's specification section so M&E suppliers do not miss this critical information.

- a. In each equipment's specification section the consultant shall;

- i. Identify the objects that are to be integrated for the equipment that the design is based on.

- 1. Preceding the list shall be a statement of *"including but not limited to. The owner reserves the right to modify the list if the equipment supplied is different than that which the design is based on, or the software that the design is based on has changed, or during the mockup information provided during the design is inconsistent with what comes through the integration."*

- ii. In the Shop Drawing section include the statement:

- 1. *At the supplier's cost, including that of the Campus BMS Company, Supplier must install/mock up a live installation and integrate it into the Campus BMS to demonstrate that it meets the BACnet specification. Failure to integrate successfully will result in rejected shop drawings.*

- B. Process for defining objects to be integrated:

BMS Contractor will work with the Consultant and the University to:

Obtain the object list from the University's inventory of previous integrations

Or

For Equipment / Systems not previously integrated, Building Management System (BMS) Contractor shall facilitate the following process and when

Div 23(a) - HVAC Design Guidelines 2024 05 15 (5)

completed, turn over to the University the outcomes for archiving and future implementation.

1. Obtain from the Equipment / System supplier a summary of what information can be integrated complete with detailed descriptions of what each piece of information means.
2. Obtain from the Equipment / System supplier the Sequence of Operation for each System that is to be integrated.
3. The University will review Items 1 & 2 and advise BMS Contractor what is to be integrated and displayed on Graphics.
4. If BMS Contractor needs to integrate more information than requested by the University, it shall be placed in the All Items Tab of the BMS.
5. Facilitate and participate in joint training with the supplier for the Integrated Equipment / System to ensure what was integrated is understood, appropriately documented and displayed in the BMS.

The above process shall apply for any firmware/software changes to previously integrated equipment. In this case, only the 'changes' are to be submitted for the University's consideration.

Div 23(a) - HVAC Design Guidelines 2024 05 15 (5)

23 05 19 Meters and Gauges for HVAC Piping

- A. All utility expenditures in new buildings shall be metered and connected via electronic data conversion to the applicable University Building Management and Control System (Johnson Controls Metasys or Delta EnteliWEB) and the University's Energy Management Information System (EMIS).
- B. These are the units and their compulsory units of measurement;
- Electricity Demand Kilowatts kW
 - Electricity Consumption Kilowatt hours kWh
 - Water Litres/Min
 - Condensate Litres/Min
 - Chilled Water Kilowatt hours (kWh)
 - Hot Fluid
 (Water, Glycol/Water) Kilowatt hours (kWh)
 - Steam Lbs/hour
 - Solar Thermal (air or water) Kilowatt hours (kWh)
- C. Applications:
- a. Electricity
- i. ION meter(s) physically installed and connected to the University Network via:

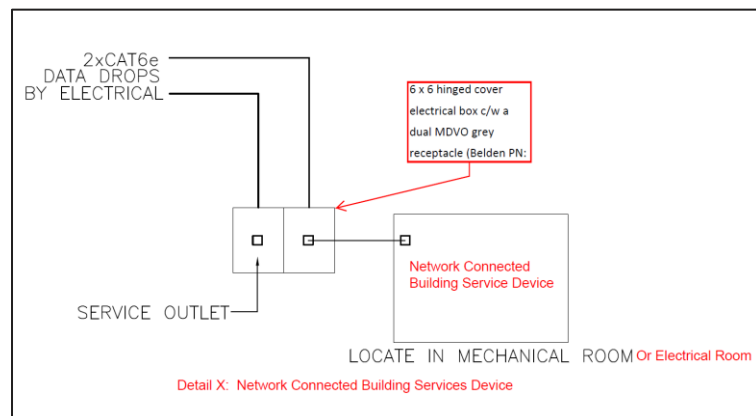

Belden PN: AX101063

- ii. University's Network Device Connection process shall be followed by the provider of the network device.
- iii. ION meter added to Schneider SQL server
- iv. Controls and Equipment (C&E) finds the ION meter and adds to EMIS (Creates Entelliweb BACnet points for kW & kWh)

Div 23(a) - HVAC Design Guidelines 2024 05 15 (5)

- v. JCI (Metasys) finds the points in the C580-B600-ebMGR01 location and adds to Metasys
 - 1. All current electrical meters (in Metasys) are found at: NAE-10>Bacnet IP1>C580-B600-ebMGR01.
- b. Water
 - i. Via Halifax Regional Water Commission Revenue Meter's Signal Duplicator to be supplied by the Building Management System Contractor.
 - 1. 4 – 20 mA signal
 - 2. Arrange for signal duplicator via Halifax Regional Water Commission. Last Contact Info: Corey Whalen, Supervisor of Metering, coreyw@halifaxwater.ca, 902 490-5472, 902 441-1145 (Cell)
 - ii. Meters are configured as per the University's Utility Meter Standard within the University's Metasys Building Management System
 - iii. Each meter's object information is provided to Controls & Equipment who define each in enteliWEB and then in the University's EMIS.
- c. Thermal Energy
 - i. Meters are supplied, installed and configured as per the University's Utility Meter Standard within the University's Metasys Building Management System
 - ii. Each meter's object information is provided to Controls & Equipment who define each in enteliWEB and then in the University's EMIS.

23 05 19.13 Thermometers and Pressure Gauges - Piping Systems

- A. Pressure readings across hydronic devices shall be accomplished using a single gauge and appropriate valve system so as to eliminate gauge to gauge inaccuracies. See examples below for a Heat Exchanger and a pump. Other types of devices shall be similar.

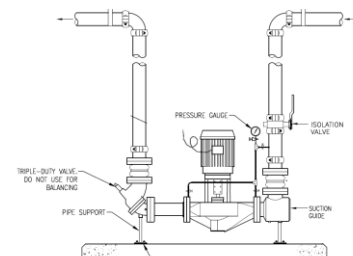
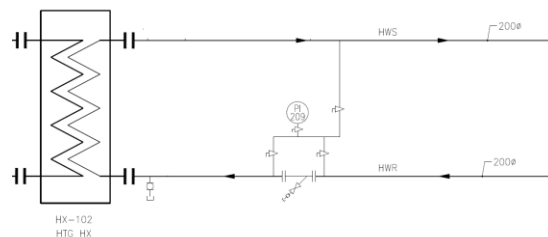

Div 23(a) - HVAC Design Guidelines 2024 05 15 (5)

B. MNS Part 2, 2.1 General shall include for gauge ranges:

Thermometers

Chilled Water	0 – 100 F
Hot Water	0 – 250 F
Domestic Hot Water	0 – 200 F

Pressure Gauges

Designer to produce a schedule of scales, ranges, scale divisions for gauges.

Mid-point to be the design point for the measurement location.
Scale to be 2 times the mid-point or the closest higher standard gauge range of 0 – 60 PSI, 0 – 100 PSI, or – 150 PSI.

23 05 53 Identification for HVAC Piping and Equipment

- A. Refer to the Facilities Management Website for the separate guideline for Mechanical Identification.

23 07 13 Duct Insulation

- A. All exterior insulation shall be complete with an aluminum jacket, self-adhering peel and stick flexible weatherproof claddings shall not be acceptable.

23 07 19 HVAC Piping Insulation

- A. Wherever damage to the insulation jacketing is possible (e.g. within 4'-0" of the floor within mechanical rooms, etc.), the insulation shall be installed complete with a canvas jacket, otherwise insulation shall be complete with a PVC jacket.

23 09 23.14 Flow Instruments

- A. Air or fluid flow Measurement and/or Metering:

Designer shall have a detail on the Mechanical Plumbing, Heating or Ventilation drawings, for each meter type, illustrating the minimum dimensional requirements of each meter type that is the basis of their design or any approved alternatives.

Further, the designer must indicate on the Plumbing, Heating or Ventilation drawing specifically where each meter specified is to be physically installed. They must ensure that the requirements of in their detail can be achieved in each of their chosen location(s).

Div 23(a) - HVAC Design Guidelines 2024 05 15 (5)

23 09 43 Pneumatic Control System for HVAC

- A. For building HVAC controls the design consultant shall discuss requirements with Owner and Johnson Controls for Halifax Campuses and Controls & Equipment for the Agricultural Campus. The Building Management System company, at no cost to the design team, shall work with the design consultant to fully engineer the system prior to tender. The Owner shall then decide how to procure the supply and installation.
- B. Actuators for steam control valves shall be specified to be installed at 45 degrees from the vertical to reduce their exposure to heat.
- C. Pneumatic Air Compressor/Compressed Air Systems
 - a. The University has central compressed air systems with clean, dry, oil-free air for all Halifax Campuses. These systems shall be used for compressed air.
 - i. No new air compressor equipment shall be installed without approval from the University Project Manager.
 - b. For the Agricultural Campus, new compressors shall be rotary screw type only
 - c. All new compressed air systems shall supply clean, dry, oil-free control air to the pneumatic control system

23 21 13.01 Hydronic Systems: Copper AND 23 21 13.02 Hydronic Systems: Steel

- A. Design
 - a. Piping systems shall be designed using the two (2) pipe direct return principle. Exceptions, requiring permission from the University's Project Manager, may be Process or Continuous that are singular process variable in nature, rather than multiple and intermittent.
 - b. Hydronic systems shall be designed with 2-way modulating control valves at each terminal device. Terminal level balancing valves or circuit setters are not to be used. System level balancing valves or circuit setters are to be justified in writing and require permission from the University's Project Manager.
 - c. A central bypass control valve with differential pressure control is not permitted. Equipment minimum flow requirements shall be reviewed and a suitable design approach shall be proposed to the University Project Manager as part of the Basis of Design.
 - d. The Testing, Adjusting & Balancing specification shall call for the requirement to use a portable Ultrasonic Flow meter for fluid balancing/flow verification.
- B. All hot & chilled water systems, glycol/water systems: Use full port ball valves up to 2". Use gate for larger pipe sizes. Use globe valves for any control valve or PRV bypass lines.
- C. Pipes and pipe fittings are to be in accordance with the following tables:

Div 23(a) - HVAC Design Guidelines 2024 05 15 (5)

Chilled Water, Hot Water, Glycol/Water Piping			
Service	Pipe Material	Fittings	Joints
Over 10", inside building or tunnel	Sch40	Welded Fitting	Welded
10" to 2", inside building or tunnel	Sch40	Mechanical Grooved or Black Iron Welded	Mechanical Grooved or welded
Less than 2" inside building or tunnel	Sch40	Black Iron Threaded	Threaded

Main distribution piping shall be iron to as close as possible to the terminal device. Copper branch lines are not acceptable.

For Mechanical Grooved applications, installation specifications shall state the following as a minimum:

Mechanical Grooved

Mechanical Grooved joints shall be installed in accordance with the manufacturer's latest published instructions. The gasket style and elastomeric material (grade) shall be verified as suitable for the intended service during the shop drawing review process. Gaskets shall be molded and produced by the grooved coupling manufacturer. As a minimum, couplings with high temperature gaskets (250F) are to be used. Grooved ends shall be clean and free from indentations, projections, and roll marks in the area from pipe end to groove. The Mechanical Grooved coupling manufacturer's factory trained field representative shall provide on-site training for each of installing contractor's field personnel used on the project in the proper use of grooving tools, application of groove, and installation of grooved piping products. (Grooving tools shall be of the same manufacturer as the fittings and couplings.). Training must take place prior to any installation of grooved product. A list of attendees who have satisfied training requirements for the project will be provided to the Owner, Engineer and Contractor. Mechanical Grooved product installed by an individual found not to have satisfied training will be removed and reinstalled by trained persons at the cost of the contractor. A factory trained representative shall periodically visit the jobsite to ensure best practices in mechanical grooved product installation are being followed. Contractor shall remove and replace any improperly installed products.

Div 23(a) - HVAC Design Guidelines 2024 05 15 (5)

Systems shall be designed in accordance with the coupling manufacturer's design guidelines associated with thermal expansion and contraction. The final layout shall be reviewed by a professional engineer employed, or retained, by the coupling manufacturer. This resource shall submit a written confirmation of this review to the Project Engineer for their review & approval, prior to installation.

23 21 23 Hydronic Pumps

- A. Heating & Cooling Pump Sets
 - a. Individual pumps are to be sized for 50% duty and it will require two pumps operating together to achieve 100% design flow.

23 22 13 Steam and Condensate Heating Piping

- A. Steam supply lines are to be adequately sized for hot water service of the same heating capacity.
- B. Condensate lines are to be equal in size to the steam supply lines.

Eventual Hot Water Design Specifications:

Description	Unit	Hot Water Side
Design Pressure	kPa	1600
Operating Pressure	kPa	TBD
Design Supply Temp.	°C	100
Max Operating Supply Temp.	°C	95
Operating Return Temp.	°C	70
Temperature Differential	°C	25
Maximum Pressure Drop Through Heat Exchanger	kPa	100

23 22 13.13 High Pressure Steam and Condensate Heating Piping Systems

- A. Pipe supports in areas that may become exposed to moisture shall be, as a minimum, hot dipped galvanized where any welds or cuts are touched up to the same grade as the hot dipped galvanized.
- B. High pressure steam traps shall be of bimetallic type, with stainless steel interior construction.
- C. High pressure steam lines must be designed with double block and bleed isolation systems.

Div 23(a) - HVAC Design Guidelines 2024 05 15 (5)

23 23 00 Refrigerant Piping

- A. Piping for refrigerants shall have no flared joints for pipe above 3/16 inches. (Justification is there will be less chance of leaks)

23 30 00 HVAC Air Distribution

When running new ductwork in an existing building, the designer and installing contractor must respect the University's and CEC requirements around cable trays and wire baskets.

There must be at least 4 inches of vertical space between the suspended ceiling tile and the bottom of the cable tray or wire basket. All other clearances around cable trays or wire baskets shall meet or exceed the latest version of the Canadian Electrical Code.

Below is an excerpt of CEC as of Nov 2020.

- ~~(5) Cable trays shall be adequately supported by non-combustible supports.~~
- (6) The minimum clearances for cable trays shall be
- (a) 150 mm vertical clearance, excluding the depth of the cable trays, between cable trays installed in tiers except that, where cables of 50 mm diameter or greater may be installed, the clearance shall be 300 mm;
 - (b) 300 mm vertical clearance from the top of the cable tray to all ceilings, heating ducts, and heating equipment and 150 mm for short length obstructions;
 - (c) 600 mm horizontal clearance on one side of cable trays mounted adjacent to one another or to walls or other obstructions, where the width of the cable tray installation does not exceed 1 m; and
 - (d) 600 mm horizontal clearance on each side of cable trays mounted adjacent to one another, where the width of the cable tray installation exceeds 1 m.

12

23 33 00 Air Duct Accessories – Flexible Connectors

All air moving shall be installed complete with flexible connections. Flexible connectors shall be a coated woven fabric, preassembled metal to exposed fabric to metal joined by means of a double lock seam and of a material suitable for the application. Standard of acceptance is neoprene steel reinforced - Duro-Dyne Neoprene (Specification Grade)

23 33 15 Dampers - Operating

Air Volume Dampers for AHUs:

Tamco 9000 for all outdoor air dampers and Tamco 1000 for Return & Exhaust air dampers

Or

Ruskin TDE50CE for outdoor air dampers and the equivalent of Tamco 1000 for Return & Exhaust air dampers.

Div 23(a) - HVAC Design Guidelines 2024 05 15 (5)

23 33 46 Flexible Ducts

- A. Any flexible duct shall be limited to no greater than 6 feet in length.
- B. Any flexible duct shall be rated for the air pressure it will be exposed to plus a minimum of 100% more.

23 34 23.13 Packaged Roof and Wall Exhausters

- A. Vortex fans for fume hood exhaust shall have the following isolation damper specifications as a minimum:
 - a. Frame shall be 16 gauge 304L Stainless steel structural hat channel with reinforced corners for strength.
 - b. The blades shall be 6" single skin, 16 gauge stainless steel 304L with three longitudinal grooves to reduce deflection.
 - c. Bearings shall be corrosion resistant, 316 stainless steel sleeve type turning in an extruded hole in the damper frame.
 - d. Axis shall be hexagonal positively locked into the damper blade.
 - e. Linkage shall be concealed out of the airstream, within the damper frame to reduce pressure drop and noise.
 - f. Blade edge seals shall be silicone, Damper construction suitable for -58 deg. C to 135 deg. C mechanically locked into the blade edge.
 - g. Jamb seals shall be stainless steel compression type to prevent leakage between blade end and damper frame.
 - h. Multiple section dampers must have factory installed jackshafts unless clearly eliminated by the engineer.
- B. Vortex fans for fume hood must have a maintenance and repair crane, for safe work.
- C. Other than Fume Hood Exhaust Fans, Exhaust Fans shall be placed in mechanical spaces, not occupied or finished spaces, and positioned as close to the exterior of a building as possible
- D. Belt-driven fans shall be equipped with a ribbed pulley, timing belt drive system. Silent Sync (<https://goodyearrubberproducts.com/2018pdfs/Contitech%20PTP%20Catalog%202017/index.html#page=1>) or alternative acceptable to the University. V-Belt based systems are not permitted.

23 36 00 Air Terminal Units

- A. Heat pumps shall be installed in mechanical rooms in new buildings for easy access and removal when required.
- B. All heat pump filters should be pleated type. Cleanable filters/screens are not permitted.
- C. Provide a means of draining for all heat/cool radiators that have supply and return mains above the radiator.

Div 23(a) - HVAC Design Guidelines 2024 05 15 (5)

- D. Provide air vents and air separators at high spots in the piping systems
- E. Provide a (ball valve) shut-off valve at supply and return connections of radiators. Radiators need to be isolated to one unit. (Any hydronic coil should be isolated).
- F. Pressure Independent Venturi Valves are only to be specified in critical airflow applications – multi-function labs, chemical wet labs, health care environments, etc. In environments where critical airflow is not required (hallways, offices, meeting rooms, classrooms, lounges etc), standard VAV boxes should be used. Clarification should be sought from the University Project Manager on a case by case basis.
- G. Venturi Air Valve Installations

Installation shall comply with the following detail, as a minimum. Ventilation drawings shall locate each Venturi Air Valve, validating that the required straight duct runs below are achievable.

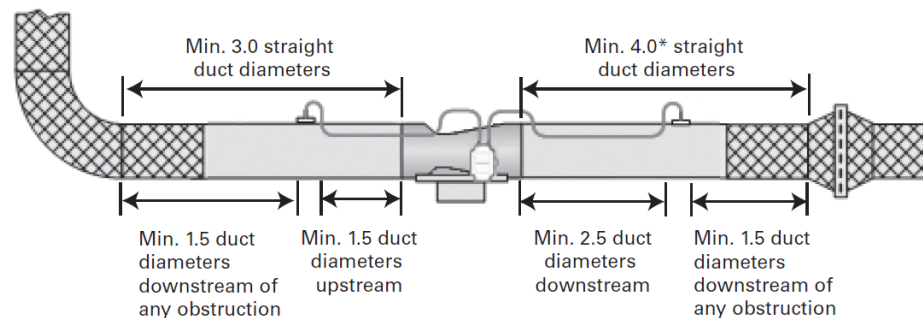

*ANSI/ASHRAE standard exceeded by FSR100 product requirement

Designer shall specify that the TAB Contractor shall measure the static pressure drop, at the sensing locations above, for each Venturi Air Valve at its, and the entire air system's, maximum design flow and document it beside the manufacturer's required static pressure drop operating range in the TAB report.

23 37 13 Diffusers, Registers and Grilles

- A. Where airside heating is provided within a space, the supply air shall delivered by linear diffusers and be located at the perimeter. The consultant shall verify the vertical exit air velocity is sufficient to push the airflow to the finished floor elevation by calculation and installation process within the specifications for any required insertions to achieve desired velocity.

Div 23(a) - HVAC Design Guidelines 2024 05 15 (5)

23 57 00 Heat Exchangers for HVAC

- A. Heat Exchangers shall be plate & frame only. Shell & tube are not permitted.
- B. Where a Steam to Hot Water plate & frame heat exchanger is required, its footprint shall accommodate a future Hot Water to Hot Water heat exchanger.
- C. Fluid to fluid heat exchangers, at design conditions, shall have an approach of no greater than 3C

23 65 10 Condensers, Coolers and Cooling Towers

- A. Refrigeration or Air conditioning equipment shall not use once-through domestic water for cooling (Justification: sustainability and water consumption savings)
- B. Provide heat rejection in the following priority
 - a. Fluid Cooler (Water/Propylene glycol only) and beneficial use of the heat within the building.
 - b. Air Cooled Condenser
 - c. Geothermal loop
 - d. If domestic water cooling must be used, the justification will need to be approved by the Project Manager
- C. Adiabatic Fluid Coolers
 - a. Water Control

The water control valve shall be in a mechanical room or other service area that has easy access. An automatic drain control valve and piping to drain for season shutdown that avoids the potential for freezing is required.
- D. Cooling Towers
 - a. Isolation Valves

Motorized Isolation Valves shall be installed so as to isolate and drain tower cells when their capacity is not required.
 - b. Vibration Sensor

Installed on the cross beam that holds the fan motor.

These are to be commissioned when the tower has its design operating water Volume/flow within it, the tower has been leveled and the vibration isolators have been adjusted with the above completed/in place.
 - c. Top Hot Water Basin – Uniform Flow Distribution for multi cell towers

Piping to each cell is to be precisely symmetrical to result in identical pressure drop/flow to each tower cell.

Div 23(a) - HVAC Design Guidelines 2024 05 15 (5)

If the Tower is intended to be operated during freezing conditions, Nozzle Cups shall be installed in sufficient quantity on top of the inboard nozzles.

Bottom inlet configuration rather than up the side of the tower.

Bottom inlet configuration is preferred where the supply pipe comes from under the roof, through the tower and to the Top Hot Water Basin.

The balancing valve for each cell shall be installed beneath the roof and insodoing always have a backpressure on it allowing it to work better/properly.

The vertical pipe that runs through the tower would have a 'weep hole' drilled in it to allow the standing water column to drain back into the basin when the condenser pump is off or the tower cell is isolated.

d. Hot Basin Water Level

Basin water level shall be tested to ensure it meets the manufacture's requirements for the specific nozzle installation.

e. Makeup water control

Water Level Control shall be by Electronic Water Level Sensor. Float valves are not acceptable. The makeup water control valve shall be in a mechanical room or other service area that has easy access. An automatic drain control valve and piping to drain for season shutdown that avoids the potential for freezing is required.

f. Multiple Cell Cold Water Basin Equalization:

Use a Flume Box if the cells are connected to each other

If the cells are not connected, use an appropriately sized pipe.

g. Proper Nozzle Size

Nozzles are sized for a specific condenser water flow rate.

Use of multiple nozzle sizes for a cell or tower section, is prohibited.

h. Gearboxes

Gearboxes require a minimum Hz of 14 for the gearbox to properly lubricate itself. This is for Marely, confirm for other manufacturers.

Gearbox oil shall be synthetic based only.

i. Miscellaneous

Hot and Cold water basins shall be stainless steel.

The tower supply and return piping shall be heat traced.

Div 23(a) - HVAC Design Guidelines 2024 05 15 (5)

All towers shall have safety gates within the Fan Deck safety rail system opening to the access ladder.

23 72 00 Air-To-Air Energy Recovery Equipment

A. H/ERV's shall meet or exceed the following performance:

SRE and Fan Efficacy Minimum Requirements					
Climate Zone	Zone Definition	Minimum SRE at 32°F (0°C)	Minimum SRE at -13°F (-25°C)	Minimum Fan Efficacy with 32°F (0°C) supply Temperature	
Heating	Canada	65%	60%	SRE < 75%	1.2 cfm/W (0.57 L/s/W)
				SRE ≥ 75%	0.8 cfm/W (0.38 L/s/W)

- B. H/ERV's shall have a bypass to allow for economizer operation unless otherwise approved by the Owner's Project Manager
- C. Every attempt shall be made to eliminate the need for electric resistance heaters within the H/ERV design.

23 73 00.13 Air Handling - Built-Up

- A. Fresh air intake must be appropriately located so that no adjacent generated fumes (automobiles) or building generated exhausts can be re-entrained into the air system. The Engineer must comment on how this has been achieved.
- B. All Air handling units shall be 304 stainless steel from the outdoor air intake to the filter racks that shall also be 304 stainless steel.
- C. External louvers
 - a. shall be constructed of aluminum.
 - b. bird screens shall be stainless steel.

Div 23(a) - HVAC Design Guidelines 2024 05 15 (5)

- c. Replacements shall have a structural assessment as part of the design. (Justification: safety / previous history of problems)
- D. Air Filters shall be front loading self-supporting cartridge type. Side loading is not acceptable. Accessibility shall avoid confined space designation. Access doors shall be hinged. Blank off plates to ensure zero bypass around filters are not acceptable. Standard sized filters shall provide sufficient air seal.
- E. Drain pans in air handling units are to be constructed of 304 stainless steel. Pans shall slope down to drain with a minimum ¼" per foot 3-way slope and have a lip. Ends to extend to capture u-bends and headers.
- F. Drain trap height shall exceed maximum fan suction static pressure at dirty filter condition and base rails for the air handling unit must be high enough to allow proper piping of traps to the drain pan. Consultants shall provide the calculation for this and input the result into the design documents. P trap outlet to be piped to the closest drain
- G. All aluminum fin coils that could be exposed to 100% fresh air shall be constructed with corrosion protective coating such as Heresite and stainless steel frame rather than galvanized or unprotected mild steel frame.
- H. Belt-driven fans shall be equipped with a ribbed pulley, timing belt drive system. Silent Sync (<https://goodyearrubberproducts.com/2018pdfs/Contitech%20PTP%20Catalog%202017/index.html#page=1>) or alternative acceptable to the University. V-Belt based systems are not permitted.
- I. Access Doors
 - a. Door handles on both sides of door
 - b. Minimum 8" x 8" shatter proof window at 48" above finished floor
- J. Internal LED lighting, powered separately from the unit.
- K. If the unit has a dedicated condensing unit it shall be designed to provide both Cooling and Heating from the condensing unit. Electrical heating elements should only be designed for backup/secondary heating and shall not be the primary source of heating

23 73 00.16 Air Handling Units - Packaged

- A. Fresh air intake must be appropriately located so that no adjacent generated fumes (automobiles) or building generated exhausts can be re-entrained into the air system. The Engineer must comment on how this has been achieved.
- B. All Air handling units shall be 304 stainless steel from the outdoor air intake to the filter racks that shall also be 304 stainless steel.
- C. External louvers
 - a. shall be constructed of aluminum.
 - b. Bird screens shall be stainless steel
 - c. Replacements shall have a structural assessment as part of the design. (Justification: safety / previous history of problems)
- D. Air Filters shall be front loading self-supporting cartridge type. Side loading is not acceptable. Accessibility shall avoid confined space designation. Access doors shall be hinged. Blank

Div 23(a) - HVAC Design Guidelines 2024 05 15 (5)

- off plates to ensure zero bypass around filters are not acceptable. Standard sized filters shall provide sufficient air seal.
- E. Drain pans in air handling units are to be constructed of 304 stainless steel. Pans shall slope down to drain with a minimum $\frac{1}{4}$ " per foot 3-way slope and have a lip. Ends to extend to capture u-bends and headers.
 - F. Drain trap height shall exceed maximum fan suction static pressure at dirty filter condition and base rails for the air handling unit must be high enough to allow proper piping of traps to the drain pan. Consultants shall provide the calculation for this and input the result into the design documents. P trap outlet to be piped to the closest drain
 - G. All aluminum fin coils that could be exposed to 100% fresh air shall be constructed with corrosion protective coating such as Heresite and stainless steel frame rather than galvanized or unprotected mild steel frame.
 - H. Belt-driven fans shall be equipped with a ribbed pulley, timing belt drive system. Silent Sync (<https://goodyearrubberproducts.com/2018pdfs/Contitech%20PTP%20Catalog%202017/index.html#page=1>) or alternative acceptable to the University. V-Belt based systems are not permitted.
 - I. Access Doors
 - a. Door handles on both sides of door
 - b. Minimum 8" x 8" shatter proof window at 48" above finished floor
 - J. Internal LED lighting, powered separately from the unit.
 - K. If the unit has a dedicated condensing unit it shall be designed to provide both Cooling and Heating from the condensing unit. Electrical heating elements should only be designed for backup/secondary heating and shall not be the primary source of heating

23 74 00 Packaged Outdoor HVAC Equipment

- A. Fresh air intake must be appropriately located so that no adjacent generated fumes (automobiles) or building generated exhausts can be re-entrained into the air system. The Engineer must comment on how this has been achieved.
- B. Air handling units shall be placed in a penthouse where practical. Alternatives must be agreed to by the University.
- C. Weather or corrosive environment exposed air handling units require enhanced exterior construction, either of stainless steel, aluminum, or coated.
- D. Air Filters shall be front loading self-supporting cartridge type. Side loading is not acceptable. Accessibility shall avoid confined space designation. Access doors shall be hinged. Blank off plates to ensure zero bypass around filters are not acceptable. Standard sized filters shall provide sufficient air seal.
- E. Drain pans in air handling units are to be constructed of 304 stainless steel. Pans shall slope down to drain with a minimum $\frac{1}{4}$ " per foot 3-way slope and have a lip. Ends to extend to capture u-bends and headers.

Div 23(a) - HVAC Design Guidelines 2024 05 15 (5)

- F. Drain trap height shall exceed maximum fan suction static pressure at dirty filter condition and base rails for the air handling unit must be high enough to allow proper piping of traps to the drain pan. Consultants shall provide the calculation for this and input the result into the design documents. P trap outlet to be piped to the closest drain
- G. All aluminum fin coils that could be exposed to 100% fresh air shall be constructed with corrosion protective coating such as Heresite and stainless steel frame rather than galvanized or unprotected mild steel frame.
- H. Belt-driven fans shall be equipped with a ribbed pulley, timing belt drive system. Silent Sync (<https://goodyearrubberproducts.com/2018pdfs/Contitech%20PTP%20Catalog%202017/index.html#page=1>) or alternative acceptable to the University. V-Belt based systems are not permitted.
- I. Access Doors
 - a. Door handles on both sides of door
 - b. Minimum 8" x 8" shatter proof window at 48" above finished floor
- J. Internal LED lighting, powered separately from the unit.
- K. All units shall have the capability for full economizer.
- L. If the unit has a dedicated condensing unit it shall be designed to provide both Cooling and Heating from the condensing unit. Electrical heating elements should only be designed for backup/secondary heating and shall not be the primary source of heating

23 81 23 Computer Room Air Conditioning

- A. Data Centres shall have a dedicated air conditioning system with N +1 capacity.

23 81 40 Air and Water Source Heat Pumps

- A. Supply air ductwork shall always be designed for high speed or maximum air volume.
- B. Return air ductwork shall be designed for full recirculation
- C. Where practical, fan coils or heat pumps should be installed in corridors or mechanical rooms. To accommodate this, consider installing makeup air ductwork in the ceiling of finished spaces.
- D. When replacement requirements are identified, the original base building manufacturer shall be the basis of design and base bid in the tender documents.
 - a. Alternate manufacturers will be considered when a bidder provides assurance the alternate complies fully with the specifications and has provided a price reduction to use their equipment on the tender form.
 - b. Minimum Efficiency Requirements are meet or exceed those on the Efficiency Nova Scotia website:
<https://www.energycyns.ca/business/products/heating/>

Div 23(a) - HVAC Design Guidelines 2024 05 15 (5)

E. Heat Pump Supply

- a. Manufacturer shall provide factory installed controls capable of actuating a third party supplied, field installed, low voltage (24 volt), normal closed, condensing water isolation valve which will be installed by the mechanical contractor and wired by the controls contractor.
- b. The heat pump will be capable of accepting hardwired command signals from the existing Building Management System (BMS). See Figure 1
- c. The heat pump control system shall be inclusive of a manufacturer supplied current relay for fan status, whose wiring shall be available at the heat pump's terminal strip for BMS pickup. See Figure 1, D1.
- d. The heat pump shall be capable of generating a General Alarm point representing standard operational and safety alarms. See Figure 1, D2.

F. Heat Pump Installation

- a. Outdoor Air Ductwork and Damper. When specified, the outdoor air ductwork shall be connected to the suction section of the heat pump. Installation in the vicinity is not acceptable. The isolation damper shall be supplied and installed by the installation contractor complete with 24 V, two position actuator for connection to the BMS.

G. Heat Pump Controls

- a. The Controller shall be a Johnson Controls TEC capable of initiating occupied/unoccupied cooling/heating set points, on/off commands.
- b. The TEC shall be networked into the Metasys BMS
- c. The following hardware points shall be connected to the TEC (See Figure 1):
 - i. Outdoor Air Isolation Damper. Open/Close. Physically connect to the TEC's Auxiliary Contact.
 - ii. General Alarm
 - iii. Fan Command
 - iv. Fan Status
 - v. Room Temperature
 - vi. Discharge Air Temperature (10k RTD). Physically connected to the TEC's Outdoor Air Temperature sensor terminal. Field installed by Johnson Controls a minimum of 4' from the heat pump's connection to the distribution ductwork, or the final HVAC device (Reheat Coil, humidifier, etc).
 - vii. Reversing Valve Command
 - viii. Compressor Command

Div 23(a) - HVAC Design Guidelines 2024 05 15 (5)

Figure 1:

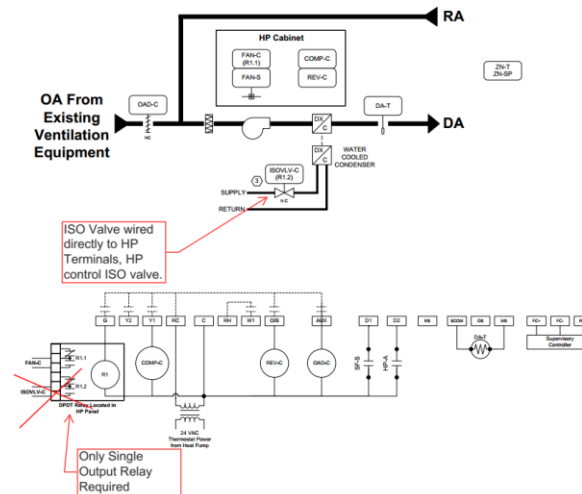

- H. If a facility's equipment is approaching the end of its useful life and the University has determined a requirement for "a wholesale replacement program":
- a. The University shall issue a RFP to suppliers outlining a phased "Supply Only" Standing Offer purchasing program for anticipated size ranges.
 - i. The bidders will be required to complete the bid form, with annual cost escalations, and honor the pricing for the duration of the Supply Only program for the specific building.
 - ii. The RFP shall state that the University has the right to use the Unit Pricing directly or assign it to an installing contractor for the specific facility.
 - iii. The overall potential quantity of units required, by project phase, if applicable, will be identified along with the planned duration of the overall program.
 - iv. Base requirements are:
 1. < Specification requirements from the Consultant for the specific project >
 2. Minimum efficiency requirements as per Section E above.
 3. As identified in Heat Pump Supply, Heat Pump Installation and Heat Pump Controls sections above.
 - v. The RFP shall request the manufacturer's standalone controls system capability/details as well as its BACnet Integration capability/details that are available as an option to the Supply Only unit pricing.

Div 23(a) - HVAC Design Guidelines 2024 05 15 (5)

23 83 02 Hot Water Radiant In-Floor

- A. Building overhangs shall have hot water/glycol radiant in floor heating.
- B. Existing building retrofits that have building overhangs without radiant in floor heating shall be brought to the attention of the University's Project Manager for direction on a suitable solution.

23 84 13 Humidifiers

- A. Humidifiers must not use central plant direct boiler steam for airstream humidification.
- B. In anticipation of converting from Central Plant Steam to Central Plant Hot Water, humidifiers shall be natural gas, or electric based. There shall not be any steam-to-steam based systems.